

filifex

friendly innovation



EASYBASKETT

MEDIUM LINE

F O O D P R O C E S S I N G E Q U I P M E N T

**TILTING KETTLES
PENTOLE RIBALTABILI
KIPPKOCHKESSEL
MARMITES BASCULANTES
MARMITAS BASCULANTES**

▶ **Cantilever version
Installazione a muro**



▶ **Floor standing version
Installazione su piedi**



■ **Gb** › **The constructive features and utilisation of quality materials guarantee top-level performances. These Boiling Pans are the easiest and simplest solution for high volume boiling: even products with a high acidity content. The jacketed heating system (indirect versions) safeguards against scorching and avoids product sticking to the bottom and sides of the pan.**

CONSTRUCTIVE FEATURES

ALL MODELS

- Bottom of the pan is constructed in AISI 316 quality stainless steel and is even suitable for boiling food products with a high acidity content.
- Exterior cladding in AISI 304 quality stainless steel.
- Motorized titling.
- Carrying structure in stainless steel aisi 304.

INDIRECT VERSIONS

- Jacket walls are in AISI 304 quality stainless steel.
- Jacket pressure is controlled by a pressure switch, vacuum valve a (0,5 bar) safety valve and pressure gauge.
- Jacket water filling assured by taps systems.
- Double-jacket control level by two luminous signals:
 - stock level (autonomy 50 min. circa);
 - inadequacy water level and alimentation block.

ELECTRIC VERSIONS

- Heated by means of armoured "Incoloy-800" elements, fitted inside the jacket.
- High heating capacities, in accordance with CE DIN 18855 Standards for "Fast cooking equipment".

GAS VERSIONS

- Heated by means of high efficiency burners stainless steel.
- Ignition by battery (1,5 V) continue flashover and pilot burner.

STEAM VERSIONS

- Heated by steam, introduced into the jacket from an external mains supply, and fitted with a control valve which provides infinite variable heat input.

■ **It** › **Le caratteristiche costruttive e l'impiego di materiali di qualità ne garantiscono elevate prestazioni. Costituiscono la risorsa più semplice ed immediata per la cottura di grandi quantità di cibi, anche ad alta acidità. Nelle versioni indirette il sistema ad intercapedine impedisce che, in fase di cottura, i prodotti attacchino al fondo ed alle pareti del recipiente.**

CARATTERISTICHE COSTRUTTIVE

TUTTI I MODELLI

- Fondo recipiente di cottura in acciaio AISI 316 spessore da 20 a 40/10, ideale per il trattamento di prodotti acidi.
- Rivestimenti esterni in acciaio AISI 304.

- Ribaltamento motorizzato su asse anteriore.
- Struttura portante in acciaio inox spessore 30/10.

INDIRETTE

- Intercapedine in AISI 304.
- Controllo pressione intercapedine a mezzo pressostato, valvola di depressione, valvola di sicurezza 0,5 bar e manometro a lettura analogica.
- Carico acqua intercapedine tramite sistema di rubinetti che garantiscono il livello ideale di acqua.
- Controllo livello intercapedine con doppia segnalazione luminosa:
 - entrata in riserva (autonomia 50 min. circa);
 - insufficienza livello acqua con conseguente blocco del sistema di alimentazione.

ELETTRICHE

- Riscaldamento con resistenze corazzate in lega "Incoloy- 800", installate all'interno dell'intercapedine.
- Potenza termica elevata, conforme agli standard prescritti dalle norme C.E. DIN 18855 per gli "Apparecchi a cottura rapida".

GAS

- Riscaldamento con bruciatori in acciaio inox ad alto rendimento.
- Accensione tramite sistema a scarica continua alimentato da una pila (1,5 v) e fiamma pilota.

VAPORE

- Alimentazione (da rete utente) tramite valvola parzializzatrice.



■ **De** Die Konstruktion und der Einsatz von Qualitätsmaterialien gewährleisten hohe Leistungen. Diese Kessel sind die leichteste und einfachste Lösung zum Kochen von grosse Mengen auch für Produkte mit hohem Säuregehalt. Das doppelwandige Heizsystem verhindert das Anbrennen am Boden und an den Seitenwänden des Kessels.

HAUPTEIGENSCHAFEN

ALLE MODELLE

- Kessel aus CNS (1.4404) geeignet für säurehaltige Speisen.
- Aussenverkleidung aus CNS (1.4301).
- Automatische Kippung.
- Tragende Struktur aus 3 mm inox.

INDIREKT

- Zwischenmantel aus CNS (1.4301).
- Druckkontrolle im Zwischenmantel durch Drucksensor, Unterdruckventil, Sicherheitsventil (auf 0,5 bar geeicht), einem Auslassventil zum Ablassen der Luft aus dem Zwischen-mantel und einem Manometer zur Kontrolle des Drucks.
- Wasserbefüllung des Zwischenmantels mit Hilfe eines Hahnsystems das den richtigen Wasserstand garantiert.
- Kontrolle des Wasserstands im Zwischenmantel durch zweifache Leuchtanzeige:

- minimaler Wasserstand (verbleibende Funktionsdauer ca.50Min.).
- Zu wenig Wasser mit Abschaltung der Heizwiderstände.

ELEKTRO

- Elektrische Beheizung durch gekapselte "Incoloy-800" Widerstände, im Inneren des Zwischenmantels angebracht.
- Hohe Heizleistung, laut den CE-DIN 18855 Normen für "Schnellkochgeräte.

GAS

- Beheizung durch Stahlbrenner mit hohem Wirkungsgrad.
- Zündung durch elektrische Zündfunken (1,5V Batterie) und Pilotflamme.

DAMPF

- Beheizung (vom Dampfnetzaus) mit einem speziellen Druckminderventil.

■ **Fr** Les caractéristiques de la construction et l'emploi de matériaux de qualité, sont la garantie de grandes prestations. Elles constituent la ressource plus simple et immédiate pour la cuisson de grande quantité d'aliments, même à haute acidité. Le système à double interstice empêche que, pendant la phase de cuisson, les produits attachent dans le fond et aux parois du récipient.

CARACTERISTIQUES IMPORTANTES

TOUTES VERSIONS

- Récipient de cuisson en acier inox AISI 316, idéal pour le traitement de produits acides.
- Revêtement externe en acier inox AISI 304.
- Renversement motorisé.
- Structure portante en acier inox AISI 304.

INDIRECTES

- Interstice en AISI 304.
- Contrôle pression double paroi par un thermostat, soupape de dépression, soupape de sécurité à 0,5 bar, une soupape de décharge et manomètre à lecture analogique.
- Chargement d'eau dans la double paroi au moyen de robinets qui garantissent le niveau idéal d'eau.
- Contrôle de niveau de la double paroi avec signalisation lumineuse:
- entrée en réserve (autonomie 50 min. à peu près);
- insuffisance niveau d'eau avec consécutif de blocage du système d'alimentation.

ELECTRIQUES

- Chauffage garanti par des résistances cuirassées en alliage "Incoloy 800", installées à l'intérieur de l'interstice.
- Puissance thermique élevée, conforme aux standards prescrits par les normes C.E.DIN 18855 pour les "Appareils à cuisson rapide".

GAZ

- Chauffage avec des brûleurs en acier inox à haut potentiel de rendement.
- Allumage par un système à décharge continue alimentée par une pile (1,5 v) et flamme pilote.

VAPEUR

- Alimentation à vapeur par l'intermédiaire d'une vanne de distribution spéciale.

■ **Es** › Las características constructivas y el empleo de materiales de calidad, garantizan elevadas prestaciones. Constituyen el recurso más simple e inmediato para la cocción de elevadas cantidades de

alimentos, aún de elevada acidez. El sistema de doble pared impide que, en fase de cocción, los productos se peguen en el fondo y en las paredes del recipiente.

CARACTERÍSTICAS PRINCIPALES

TODAS VERSIONES

- Recipiente de cocción en Acero Inox AISI 316, ideal para el tratamiento de productos ácidos.
- Doble pared y revestimiento exterior en AISI 304.
- Elevación motorizada.
- Bastidor en acero inox AISI 304.

INDIRECTO

- Intercambiador construido AISI 304.
- Control presión camisa mediante presostato, válvula de depresión, válvula de seguridad 0,5 bar y manómetro analógico.
- Carga de agua del intercambiador mediante sistema de grifos que garantizan el nivel ideal del agua.
- Control nivel camisa con doble señalización luminosa:
 - entrada en reserva (autonomía aprox. 50 m.);
 - insuficiencia nivel agua con el consiguiente bloqueo del sistema de alimentación.

ELÉCTRICO

- Calentamiento realizado mediante resistencias blindadas en aleación "Incoloy 800", instalada en el interior del intercambiador.
- Elevada potencia térmica, de acuerdo con las normas standard de la normativa C.E. DIN 18855 para los "Aparatos de cocción rápida".

GAS

- Calentamiento realizado con quemadores de alto rendimiento, construidos en Acero Inox.
- Encendido mediante descarga continua alimentado con una pila (1,5 v) y llama piloto.

VAPOR

- Alimentación (de red local) mediante válvula parcializadora.





MOD.	Dimensions Dimensioni Dimensions Abmessungen Dimensión L x P x H mm	H1 mm	Pan dim. Dim. vasca Dim. cuve Abm. Tiegel Dim. cuba mm	Useful/overall capacity Volume utile/totale Volume utile/total Volumen nutz./ges. Volumen útil/total lt	DG/IG	IE	IV
					Gas power rating Potenza gas Puissance gaz Leistung (Gas) Potencia gas kw	Elect. power rating Potenza elettrica Puissance électrique Leistung (Elektro) Potencia eléctrica kw	Steam rate flow Portata vapore Durchfluss-Dampf Débit de vapeur Caudal vapor kg/h
PMK 100	1445x1180 h. 1090	2000	Ø 600 h. 415	100 / 110	21	16	40/50
PMK 150	1445x1180 h. 1090	2000	Ø 600 h. 580	150 / 160	21	18	50/60
PMK 200	1596x1310 h. 1090	2165	Ø 750 h. 520	200 / 220	34,5	32	60/80
PMK 300	1726x1380 h. 1090	2320	Ø 900 h. 520	300 / 325	48	36	80/100
PMK 500	1726x1460 h. 1090	2320	Ø 900 h. 780	476 / 496	48	36	100/120

MODEL/MODELLO/MODELL/MODELE/MODELO

PMK...DG

- Gas (direct) heated versions
- Alimentazione gas diretta
- Direkte Gasbeheizung
- Alimentation gas, chauffage direct
- Alimentación gas directa

PMK...IG

- Gas (indirect) heated versions
- Alimentazione gas indiretta
- Indirekte Gasbeheizung
- Alimentation gas, chauffage indirect
- Alimentación gas indirecta

PMK...IE

- Electric (indirect) heated version
- Alimentazione elettrica indiretta
- Indirekte Elektroheizung
- Alimentation électrique, chauffage indirect
- Alimentación eléctrica indirecta

PMK...IV

- Steam (indirect) heated version
- Alimentazione vapore indiretta
- Indirekte Dampfheizung
- Alimentation vapeur, chauffage indirect
- Alimentación vapor indirecta

**MAIN OPTIONALS AND ACCESSORIES
PRINCIPALI ACCESSORI E OPTIONAL
ACCESSOIRES PRINCIPAUX ET OPTIONS
ZUBEHÖR UND OPTIONALS
ACCESORIOS PRINCIPALES Y EXTRAS**

- Gb** › 1 Washout butterfly valve
2 Front drain cock
3 Insulated lid
4 Basket insert
1/2/3 segments
5 Couscoussiere
6 Coffee filter
7 Milk boiling funnel
8 Strainer
• Automatic water-charge
of double-jacket

- It** › 1 Valvola di scarico a farfalla
2 Rubinetto di scarico
3 Coperchio coibentato
4 Cesto 1/2/3 settori
5 Couscoussiere
6 Filtro caffè
7 Imbuto bollilatte
8 Colino
• Carico automatico
intercapedine

- De** › 1 Scheibventil für Ablauf
2 Hahn zur Entleerung
3 Deckel thermise isoliert
4 Gemüsekorbeinsatz
1/2/3-teilig
5 Couscoussiere

- 6 Kaffeefilter
7 Milchkochtrichter
8 Sieb
• Automatische
Wasserstandskontrolle
im Zwischenmantel

- Fr** › 1 Vanne de decharge
à papillon
2 Robinet de vidange
3 Couvercle isolé
4 Panier 1/2/3 secteurs
5 Couscoussiere
6 Entonnoir café
7 Entonnoir lait
8 Passoire
• Remplissage automatique
dans la double paroi

- Es** › 1 Valvula descarga a mariposa
2 Grifo de descarga
3 Tapa aislada
4 Cesto 1/2/3 sectores
5 Couscoussiere
6 Filtro de café
7 Embudo hierva-leche
8 Colador
• Carga automática camisa
intercambiador



INSTALLATION / INSTALLAZIONE / INSTALLATION / INSTALLATION / INSTALACIÓN

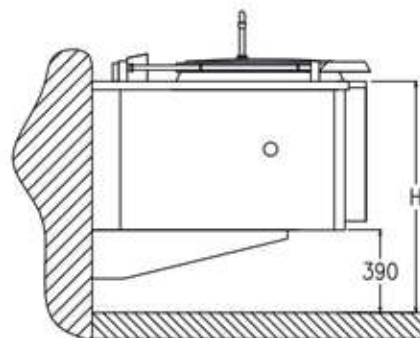
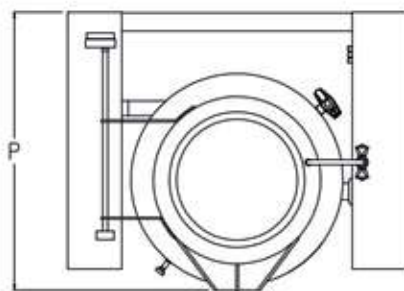
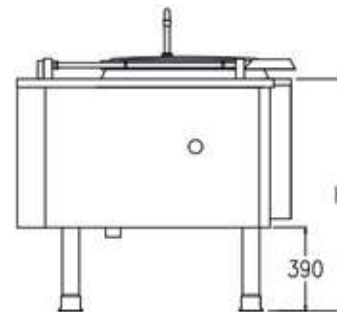
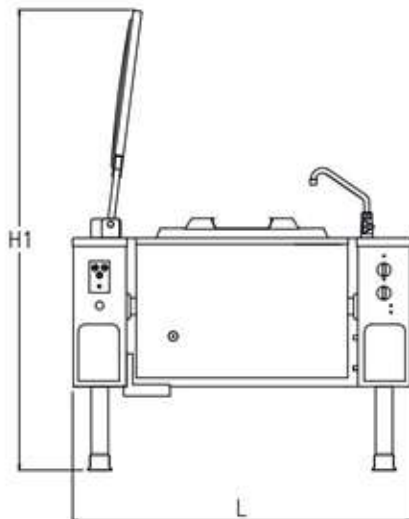

f i r e x . i t



COMPANY
WITH QUALITY MANAGEMENT
SYSTEM CERTIFIED BY DNV
= ISO 9001 : 2014 =

COMPANY WITH
SAFETY SYSTEM
CERTIFIED BY DNV
= OHSAS 18001 - 2014 =

